

ST-CVIH13H

1.3Mp Indoor IR Dome HD-CV ICamera



Features

- > 1/3" 1.3M SONY Exmor CMOS
- > Coaxial cable transmission technology
- > Auto flickerless
- > Auto day & night
- > Smart IR Control
- > HD CVI or 960H Output Optional
- > Power supply: DC12V

ST-CVIH13H**Technical Specifications**

Model	ST-CVIH13H
Image Sensor	1/3" 1.3M SONY Exmor CMOS
Signal System	NTSC/PAL
Resolution	Digital:1280×720p Analog:960H
Min. Illumination	0.01Lux@F1.2 (0Lux IR on)
Scanning System	Progressive
Synchronization	Internal
Frame Rate	50Hz:720p@25fps(1280×720) 60Hz:720p@30fps(1280×720)
Video Output	Digital: HD-CVI ; Analog: 1Vp-p Composite Output(75Ω/BNC)
S/N Ratio	≥48dB(AGC OFF)
Electronic Shutter	Auto
Day & Night	Auto
White Balance	Auto
Lens Shade	On
AGC	On
DNR	2D
IR LED	24 pcs IR LED
Lens	3.6mm/6mm
IR Range	25m
Input Voltage	DC12V±10%
Current	250mA
Power Consumption	<3.5W
Weight	175g
IP Rating	IP60
Operation temperature	-10°C~+50°C(14°F~122°F)
Operation humidity	< 85%RH (Non-condensation)

ST-CVIH13H

Dimensions (mm)

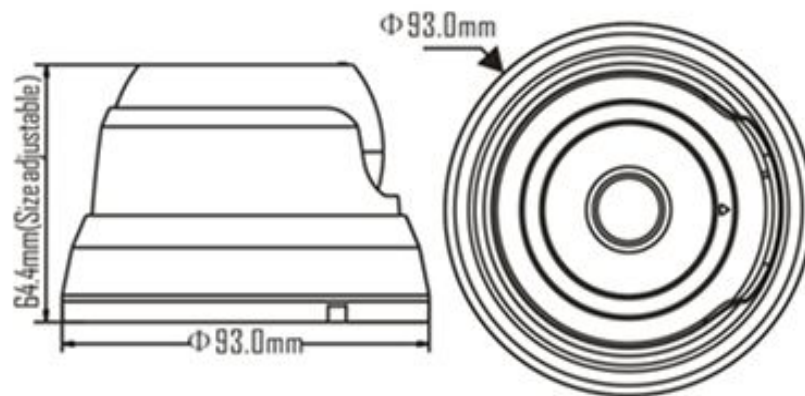

Saitell Technology Co., Ltd.

China Shenzhen Foreign Trade (Group) Building, 239 Zhongxing Road, Shenzhen, China

Tel: +86-755-22318209

Fax: +86-755-22318205

Email: sales@saitell.com

www.saitell.com

*Design and specifications are subject to change without notice.

© 2015 Saitell Technology Co., Ltd.

